

Morehouse
INSTRUMENT COMPANY, INC.



Model 4215 Smart Indicator

Morehouse Instrument Company, Inc.
1742 Sixth Ave, York PA 17403 USA
Tel: (717) 843-0081, Fax: (717) 846-4193
www.morehouseinst.com

CONTENTS

CONTENTS.....	1
INTRODUCTION.....	4
QUICK START.....	6
RUN MODE.....	8
ITEM BUTTON.....	9
TARE BUTTON.....	9
RESET BUTTON.....	9
VIEW BUTTON.....	9
PRINT BUTTON.....	10
UNIT BUTTON.....	10
SETUP MODE SUMMARY.....	11
SETUP MODE.....	12
ENTERING NUMERICAL DATA.....	13
>USER DATA ENTRY.....	13
>>Base Area Ch A.....	13
>>Base Length.....	13
>ANALOG OUTPUT CHANNELS.....	13
>SENSOR SELECT.....	14
SENSOR DELETE.....	14
>CALIBRATION.....	14
>>Cal Check.....	15
>>Cal by mV/volt.....	15
>>Cal by Masses.....	15
>>Cal by Shunt Val.....	16
>>Counts per Inch.....	16
>LIMITS.....	16
>SYSTEM OPTIONS.....	17
>>Printer Baud.....	17
>>Auto Identify.....	17
>>Auto Zero Ch A/B.....	17
>>Com Address.....	17
>>Com Baudrate.....	18
>>Com Line Feed.....	18
>>Retain Tare.....	18
>DISPLAY OPTIONS.....	18
>>Filter Select.....	18
>>Decimals Ch A/B.....	18
>>Count By Ch A/B.....	19
>>Second Line.....	19
REMOTE OPERATION.....	20
DIGITAL INPUTS.....	20
RS232 OPERATION.....	21
RS232 RUN MODE COMMAND SUMMARY.....	22

RS232 RUN MODE COMMANDS	22
HELLO COMMAND (H)	22
QUESTION MARK COMMAND (?).....	22
FRONT PANEL DISPLAY COMMAND (F).....	23
<i>Front Panel View Command (FV)</i>	23
<i>Front Panel Set Command (FS)</i>	23
<i>Front Panel Alternate Command (FA)</i>	23
VALUE COMMAND (V).....	24
PRINT COMMAND (P)	24
RESET TARE, PEAK, VALLEY, OR POSITION COMMAND (R)	26
TEXT DISPLAY COMMAND (T)	26
RS232 SETUP MODE COMMAND SUMMARY	27
RS232 SETUP MODE COMMANDS	28
USER DATA ENTRY COMMAND (U).....	28
<i>User Data View Command (UV)</i>	28
<i>User Data Area Command (UA)</i>	28
<i>User Data Length Command (UL)</i>	28
ANALOG OUTPUT COMMAND (A)	29
<i>Analog Output View Command (AV)</i>	29
<i>Analog Output Set Command (AS)</i>	29
SENSOR COMMAND (S)	29
<i>Sensor View Command (SV)</i>	30
<i>Sensor Select Command (SS)</i>	30
<i>Sensor Delete Command (SD)</i>	30
CALIBRATION COMMAND (C).....	31
<i>Calibration Check Command (CC)</i>	31
<i>Calibration Begin Command (CB)</i>	31
<i>Calibration Escape Command (CE)</i>	32
<i>Calibrate by Millivolt-Per-Volt Command for One Point (CV)</i>	32
<i>Calibrate by Millivolt-Per-Volt Command for Five Points (CMV5)</i>	33
<i>Calibrate by mV/V Mass and Volt Commands (CMVM and CMVV)</i>	33
<i>Calibrate by Masses Command (CM)</i>	34
<i>Calibrate by Masses Point Command (CMP)</i>	34
<i>Calibrate by Shunt Command (CS)</i>	35
<i>Calibrate Counts-Per-Inch Command (CI)</i>	36
LIMITS COMMAND (L).....	36
<i>Limit View Command (LiV)</i>	36
<i>Limit Set Command (LiS)</i>	36
<i>Limit Setup Escape (LE)</i>	37
<i>Limit Reset Command (LiR)</i>	38
SYSTEM OPTIONS COMMAND (O).....	38
<i>Option View Command (OV)</i>	38
<i>Option Printer Baudrate Command (OP)</i>	38
<i>Option Auto-Identify Command (OI)</i>	39
<i>Option Auto-Zeroing Command (OZ)</i>	39
<i>Option Com Address Command (OA)</i>	39
<i>Option Com Baudrate Command (OB)</i>	40
<i>Option Linefeed Command (OL)</i>	40
<i>Option Tare Retain Command (OT)</i>	40
DISPLAY OPTIONS COMMAND (D).....	40
<i>Display View Command (DV)</i>	40
<i>Display Filter Command (DF)</i>	41
<i>Display Decimal Command (DD)</i>	41

Display Count By Command (DC)..... 41
Display Second Line Command (D2)..... 41
Display Second Line Text (DT)..... 42
SYSTEM CALIBRATION MODE..... 43
FORCE AVERAGING (OPTIONAL) 44
APPENDIX A – MODEL 4215 SPECIFICATIONS 44
APPENDIX B -- CABLES AND CONNECTORS 49
SENSOR CONNECTORS..... 49
SERIAL PORT CONNECTOR 49
DIGITAL I/O CONNECTOR..... 50
CHART REC. CONNECTOR 51
PRECISION SHUNT CALIBRATION RESISTORS 52

Under the copyright laws, this publication may not be reproduced or transmitted in any form, electronic or mechanical, including photocopying, recording, storing in an information retrieval system, or translating, in whole or part, without the prior consent of Morehouse Instrument Company Inc. Copyright April 15, 2005 all rights reserved.



INTRODUCTION

The Model 4215 is a versatile precision instrument intended for the digital readout of strain gage sensors such as load cells. Optical encoders are also supported.



Here is a quick listing of its features:

- Full bi-polar **6 digit display** ($\pm 999,999$) using two line, 20 character, vacuum fluorescent display for clear, precise indication of measured quantities and limit status.
- **No knobs or dials. No internal jumpers.** All adjustment and calibration is done using user-friendly front panel menus. **Keylock** option to prevent accidental or unauthorized changes to the unit's setup.
- Measure **load** in pounds, kilograms, Newtons, PSI, MegaPascals, kilo-pounds, kilo-Newton, metric tons, mV/V, or grams. User defined base area for PSI and MPa. Tare at any time.
- Capture the load **peak** and **valley**, display in pounds, kilograms, Newtons, PSI, MegaPascals, kilo-pounds, kilo-Newton, metric tons, or mV/V. Reset at any time.
- Measure **position** and **velocity** with optional encoder input. Display in English units, metric units, or in percent of a user defined base length. Reset at any time.
- Four contact closure **Limit** switches. You can set which signal drives the limit (load, peak, valley, position, or velocity), normally open / normally closed, set point, and manual reset (latched) or automatic reset (not latched).
- **Print** current readings of load, peak, valley, position, and velocity using the currently selected units at the touch of one button.
- **Automatic identification** of calibrated load cells with auto-id option.
- **Calibration** for load cells using manufacturer's milli-volt per volt calibration factor, 5 point milli-volt per volt, 2 or 5 point known mass, or internal precision shunt calibration. A back panel switch allows you to choose between two values used for the shunt calibration so there is no need to open the unit.

- **Two Channels of Analog output** of any signal (load, peak, valley, position, velocity) with user defined scale factor and offset. Large, buffered ± 10.00 volt output.
- Remote operation using standard **RS232 ASCII** command set.
- Back panel **digital inputs** for tare, peak and valley reset, position reset, and print. Other functions available as custom programmed options.
- Optionally measure the **average force** using a contact closure to begin and end the averaging period.

QUICK START

This section will help you get your Model 4215 set up and operating in just a couple of minutes.

The back panel is shown below. You will need to make at least two connections here. First be sure that the power switch is off (the lower part of the rocker should be pressed in). Connect the AC power line and plug it in.

MODEL 4215 BACK PANEL



Next connect a load cell to the 9 pin female connector labeled “Sensor A”. You should use the cabling supplied with your Model 4215 and load cell. If you do not have a factory supplied cable see Appendix B for the recommended load cell connection.

You are now ready to turn on the power. Each time power is applied to the Model 4215 you will see a sequence of 6 messages appear on the front display. For example,

#	Message	Meaning
1	ESL .X.Y.Z	This is the version number.
2	Serial # 12345	This is the serial number.
	Option # 114236	This is the option number.
3	Last ID A 90437	The serial number of the load cell on Ch A.
	Last ID B 12030	The serial number of the sensor on Ch B
4	Ch A Max 4.00Lb	Maximum rated load of the sensor on channel A.
	Ch B Max 10.00In	Maximum rating of the sensor on channel B.
5	Ch A Cal 4.00000 mVv	The mV/V constant used with the load cell on channel A.
	Ch B Cal 4.00000 mVv	The mV/V constant used with the sensor on channel B.
		<i>Note: If either of these sensors was calibrated by 5 –Point Mass, then 4 mV/V constants will be displayed here.</i>
6	Ch A Exc 5.00 Volt	Excitation voltage used with the load cell on channel A.
	Ch B Exc 2.50 Volt	Excitation voltage used with the sensor on channel B.

Each of these messages will be displayed for about 3 seconds. After that the front display will start showing the current readings from the load cell and sensor.

To change what item is being displayed press the leftmost button. This will cycle through the list of items (Load A, Peak A, Valley A, Load B, Peak B, Valley B, Position, Velocity, Limits, optionally: Avg A, Avg B).

The rightmost button will change the units that are being used. Repeated presses of this button will cycle through the list of units available for the currently displayed item. For example, with Load A showing you would see Lb, kg, N, PSI, MPa, Klb, kN, t, mV/V, g and then back to Lb.

RUN MODE

The Model 4215 has three modes of operation, Run mode, Setup mode, and System Calibration mode. At power-on it will be in Run mode.

The first line of the display show an item label (Load A), a value (0.0000), and a unit label (Lb).

The second line of the display can show the status of the 4 contact closure limit switches, show another display, show text, or be blank.

To change what item is being displayed press the leftmost button. This will cycle through the list of items (Load A, Peak A, Vall A, Load B, Peak B, Vall B, Pos, Vel, and Limits, optionally Avg A, Avg B).

The rightmost button will change the units that are being used. Repeated presses of this button will cycle through the list of units available for the currently displayed item. For example, with Load showing you would see Lb, kg, N, PSI, MPa, Klb, kN, t, mV/V, g and then back to Lb.

The table below summarizes the options.

Load A	Pounds, Kilograms, Newtons, PSI, MegaPascals, Kilo-Pounds, Kilo-Newton, Metric Tons, mV/V, grams.
Peak A	Pounds, Kilograms, Newtons, PSI, MegaPascals, Kilo-Pounds, Kilo-Newton, Metric Tons, mV/V, grams.
Valley A	Pounds, Kilograms, Newtons, PSI, MegaPascals, Kilo-Pounds, Kilo-Newton, Metric Tons, mV/V, grams.
Load B	Pounds, Kilograms, Newtons, PSI, MegaPascals, Kilo-Pounds, Kilo-Newton, Metric Tons, mV/V, grams.
Peak B	Pounds, Kilograms, Newtons, PSI, MegaPascals, Kilo-Pounds, Kilo-Newton, Metric Tons, mV/V, grams.
Valley B	Pounds, Kilograms, Newtons, PSI, MegaPascals, Kilo-Pounds, Kilo-Newton, Metric Tons, mV/V, grams.
Position	Inches, Centimeters, Percent of Base Length.
Velocity	Inches per Minute, Centimeters per Minute.
Limits	Shows state of each switch, 1 for on, 0 for off, dash for disabled, asterisk for source error.
Avg A	Pounds, Kilograms, Newtons, PSI, MegaPascals, Kilo-Pounds, Kilo-Newton, Metric Tons, mV/V, grams.
Avg B	Pounds, Kilograms, Newtons, PSI, MegaPascals, Kilo-Pounds, Kilo-Newton, Metric Tons, mV/V, grams.

All of these measurements are acquired by the Model 4215 at all times. The display just selects which particular item you wish to see and what units are used to display or print this data.

The row of buttons have the functions indicated by the upper set of labels (Item, Tare, Reset, View, Print, Unit). Each of these is described below.

Item Button

The **Item** button cycles through the list of different items that can be displayed (Load A, Peak A, Vall A, Load B, Peak B, Vall B, Pos, Vel, Limits, and optional Avg A and Avg B). Use the **Unit** button to change the units that are used for the currently displayed item.

Tare Button

The **Tare** button sets the current load to zero for channel A, channel B, or channels A **and** B. A submenu will allow you to select what channel you want to tare. It does not matter what is being displayed when you press this button. The load is always reset to zero. A single channel unit will automatically set Load A to zero.

Reset Button

The **Reset** button brings up a list of things that you might want to set to zero:

If this is a 2-channel unit, the following menu will appear:

- > *Reset Ch A + Ch B* will reset the peak, valley, max, min for channels A and B.
- > *Reset Ch A Only* will reset the peak and valley for channel A.
- > *Reset Ch B Only* will reset the max and min for channel B.
- > *Reset Position* will reset the position to zero.
- > *Reset Limits* will reset any limits that require manual resetting.

For a single channel unit, the following menu will appear:

- > *Reset Peak+Vall* will reset the peak and valley measurements.
- > *Reset Peak Only* will reset the peak measurement.
- > *Reset Vall Only* will reset the valley measurement.
- > *Reset Position* will reset the position to zero.
- > *Reset Limits* will reset any limits that require manual resetting.

Pressing either the “+” button or the “>” button will scroll forward through this list. Pressing either the “-” button or the “<” button will scroll backward through the list. Pressing “**Enter**” will reset the currently displayed item. Pressing “**Esc**” will return to Run Mode without resetting anything. Note that all menu lists on the Model 4215 start with the “>” symbol and that the **Esc** button will always back out of a menu without making any changes.

View Button

The **View** button switches between two virtual displays stored in the memory. Each of these displays will remember the units you have selected for each item, and which item is currently being shown. This may save you from scrolling through the list of items if there are two particular results that you often use. For instance you might set the display to show Load in Lb, press **View**, and then set the display for Peak in PSI. Repeated presses of the **View** button will now switch back and forth between Load in Lb and Peak in PSI with a single button push. If

you choose to have the second line show a display, then the **View** button toggles between the display currently being activated. The activated display will have a “>” symbol to the left of it.

Print Button

The **Print** button will send a set of data to the printer. This will contain the current readings of load, peak, valley, position, velocity, and limit status. The units used for printing will be the units last selected on the numerical display.

The printer must be a serial printer that supports ESC/P protocol. Many Epson printers with serial ports are known to be compatible.

Appendix B gives the pin assignments on the serial connector.

Unit Button

The **Unit** button cycles through the list of units that are available for the item that is currently being displayed.

SETUP MODE SUMMARY

The table below summarizes the setup mode menus. Detailed information about each individual item is presented in the following sections.

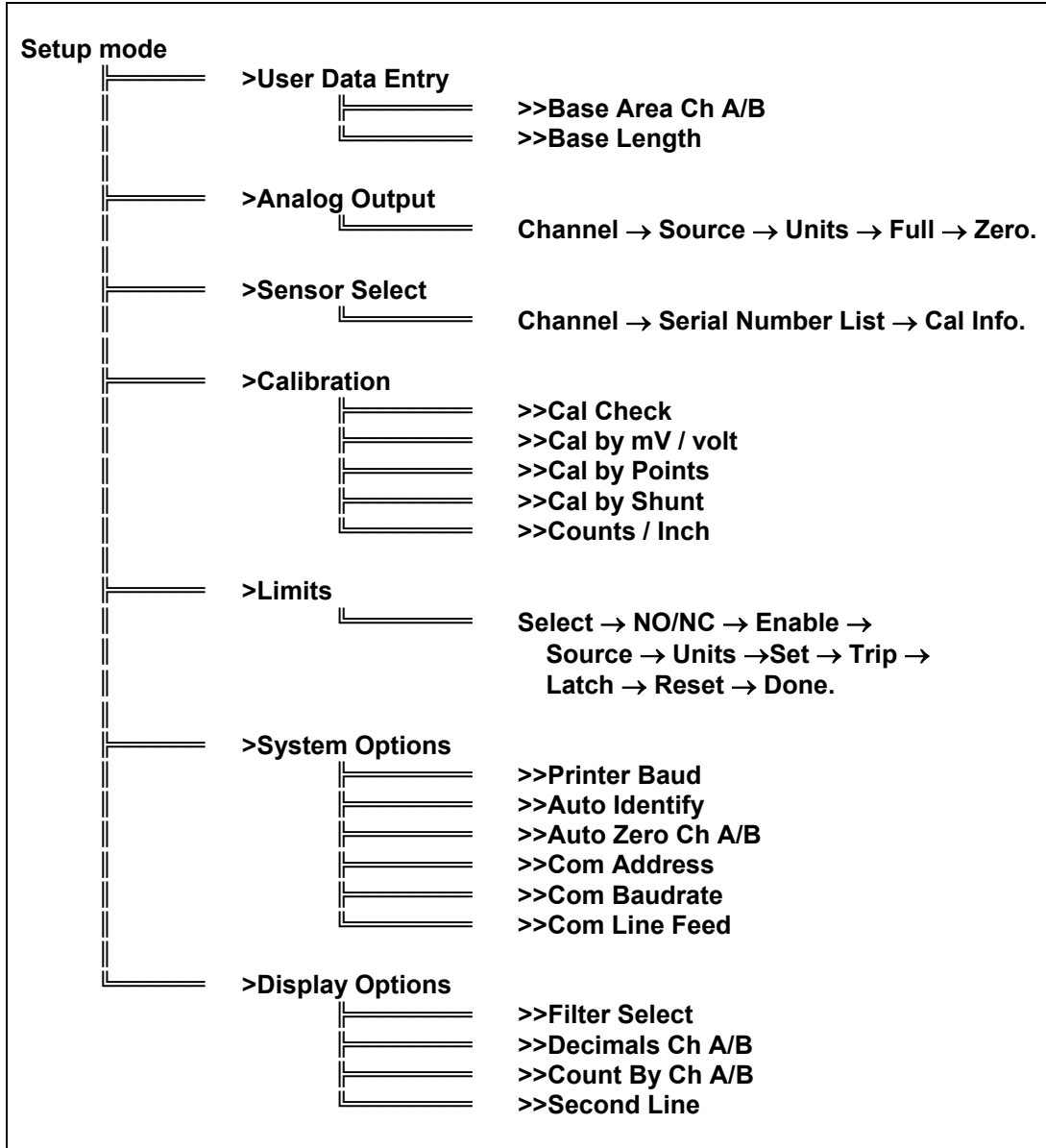

SETUP MODE

Setup mode is used to change the setup of the Model 4215. To enter setup mode press the two end buttons at the same time (“<” and “>”). The row of four buttons will now function as indicated by the lower set of labels (Plus, Minus, Enter, and Escape).

If the optional keylock is in the locked position you will see “>Setup is Locked” when you try to enter setup mode. This prevents accidental or unauthorized changes to the setup of the unit.

To exit from setup mode and return to run mode press the escape button (Esc). When you are entering numerical data or selecting options from a sub-menu the escape button will back you out without making any changes.

The main menu in setup mode contains the following 6 entries which will be described in detail in the following sections. Note that all main menu items begin with the “>” symbol and that all submenu items begin with the “>>” symbol.

- **> User Data Entry** -- allows you to set any common math options such as the base area used to display load in PSI or the base length used to display position in percent.
- **> Analog Output** -- is used to select the analog channel, source, and scaling for the analog output channels.
- **> Sensor Select** -- lets you manually set which load cell calibration data is used. If you use auto-id load cells you will never need this menu.
- **> Calibration** -- provides access to calibration for load cells, extension sensor, or optical encoders.
- **> Limits** -- allows you to set the source and options for the 4 contact closure switches.
- **> System Options** -- contains entries to set the printer baud rate, enable or disable automatic sensor identification, enable or disable automatic load zeroing, and to set the serial communications address, baud rate, and line feed options.
- **> Display Options** -- lets you choose the filtering that is applied to the load measurements, the number of decimal digits that are shown on the display and on the print, the count by values for channels A and B (1, 2, 5, 10, or 20), and whether the second line of the display shows the limit switch status, a blank line, another display, or text.

The Plus or Right button (“+” or “>”) will scroll forward through this menu. The Minus or Left button (“-” or “<”) will scroll backward through this menu. The **Enter** button selects the currently displayed menu item. The **Esc** button will return you to Run Mode.

Entering Numerical Data

At times you will need to enter numerical data into the Model 4215. The method is consistent in all cases. A number is presented on the left side of the display with an underline cursor.

- **Left** (“<”) moves the cursor left one position. If you are on the leftmost digit a new zero will be added. Thus 10.000 will become 010.00 where the cursor has moved from the tens place to the hundreds place.
- **Right** (“>”) moves the cursor right one position. If you are at the far right a new decimal will be added if there is room. Thus 12.34 will become 12.340 where the cursor has moved from the tenths to the hundredths place.
- **Plus** (“+”) increments the digit above the cursor. Thus 12.34 becomes 13.34. Note that 9 will “wrap around” to 0.
- **Minus** (“-”) decrements the digit above the cursor. Thus 12.34 becomes 11.34. Note that 0 will “wrap around” to 9.
- **Plus and Minus** (both “+” and “-” at the same time). This will change the sign of the number. Thus 12.34 becomes -12.34. Note that cursor position does not matter when you change the sign.
- **Enter** accepts the currently displayed number.
- **Esc** escapes from numerical entry and discards any changes that have been made.

>User Data Entry

This menu is used to enter numerical constants used by the math options. These constants are listed in a submenu that works exactly like the main setup mode menu. Typical items in this submenu are:

>>Base Area Ch A

This is the area in square inches that is used to calculate load in pounds per square inch (PSI) or Mega Pascals (MPa).

>>Base Length

This is the length in inches that is used to calculate position in percent.

>Analog Output Channels

This menu is used to set up the analog outputs. Instead of a submenu there is a series of selections. Pressing escape at any time will leave the analog output unchanged and return you to the setup mode main menu.

1. **Channel:** -- This entry allows you to select the analog output channel A or B. (use either the left/right or plus/minus buttons) for the selected source data that will drive the analog output. Press enter to select the displayed Analog channel.
2. **Source:** -- This entry allows you to scroll through a list (using the left/right or plus/minus buttons) to select the source of the data that will drive the analog output. The standard list will include load, peak, valley, position, and velocity. Press enter to select the displayed item.
3. **Units:** -- This entry allows you to scroll through the list of available units for the data source you have chosen in the previous step.

4. **Full** -- This entry specifies the value of source data (in the selected units) that will cause the Model 4215 to output positive full scale analog voltage (+10.0 volts).
5. **Zero** -- This entry specifies the value of source data (in the selected units) that will cause the Model 4215 to output zero analog voltage (0.0 volts).

Once you have entered these 4 selections the analog output is setup.

>Sensor Select

This menu is used to manually select load cell calibration data from a list stored in the Model 4215. When you select this menu on a 2 channel unit, you are asked to select Channel A or B. The load cell serial number of the selected channel is displayed. Use either the left/right or plus/minus buttons to page through the list. The escape button will return to the setup mode main menu without changing the load cell that is selected. The enter button will select the currently displayed load cell and briefly display the rated load, last calibration date, and excitation voltage.

To add new load cells to this list use the Calibration entry on the setup mode main menu described below.

If you are using auto-id load cells this menu will allow you to see which load cell is selected but will not allow you to change the selection. This ensures that the correct calibration information is always used when you use Auto-ID load cells.

Sensor Delete

The Model 4215 can store calibration data for 4 different load cells / sensors (25 slots optional). To delete a load cell from this list choose ">Sensor Select" from the setup mode main menu. Press the left/right or plus/minus keys until the serial number of the cell you wish to delete is displayed. (You may need to shut off auto-id if it is on, see the System Options menu for details). Then press both the plus and minus keys at the same time. The Model 4215 will ask "Delete Sensor?" to be sure that you intend to delete this calibration data. Pressing Enter will delete the cell data from the list. Pressing Escape will return to the load cell select without changing the list.

>Calibration

This menu is used to access all methods of calibration that are supported by the Model 4215. Selecting calibration from the setup mode main menu will bring up a submenu. This submenu is used exactly like the main menu. Press left/right or plus/minus to change the menu item. Press escape to return to the setup mode main menu. Press enter to select the displayed menu item.

If you are re-calibrating a load cell, the Model 4215 will recognize it using either the auto-id or a manually entered serial number. Any time you overwrite existing load cell calibration data you will first be warned with the "Overwrite Data?" message. Pressing enter will overwrite; pressing escape will cancel the calibration. Another method of overwriting existing data is to delete the sensor first and then calibrate.

If a load cell with a new serial number (or new auto-id) is calibrated the data is added as a new entry in the load cell list.

>>Cal Check

Selecting this item will run a calibration check on the load cell / sensor attached to Channel A or B. The Model 4215 will measure the shunt value of the load cell and compare it to the shunt value that was recorded when the load cell was last calibrated. The rated load and last calibration date for the load cell are displayed followed by the currently measured shunt value and the shunt value that was recorded when the load cell was calibrated.

Note that the Model 4215 has a switch on the back panel that allows you to select either a 30K shunt or a 60K shunt. Be sure that this switch is set correctly for the load cell that you are using.

Since this shunt check electronically applies approximately half the rated load, it is important that the load cell / sensor is not loaded when this check is run. If you see the "Cell Overloaded" message, remove any load on the cell and try the check again.

>>Cal by mV/volt

This item is used to calibrate a cell using the manufacturer's milli-volt per volt calibration factor or a series of milli-volt per volt points with corresponding masses (usually listed on the load cell calibration certificate). Before you enter in the desired information, another menu will ask if you want to calibrate by **milli-volt per volt** or **5 Point milli-volt per volt**. You will be asked for the channel, the cell serial number, the current date, the calibration unit, the cell's maximum rated load, and the desired excitation voltage (5.0 or 10.0 volts). If milli-volt per volt calibration was selected, you are then prompted to enter the manufacturer's milli-volt value. If **5 point milli-volt per volt** calibration was selected, you are prompted for each mass and milli-volt per volt value. One of these points should be zero mass and zero milli-volts per volt. Enter each of these selections or press the escape button at any time to return to the setup mode main menu without changing the calibration. The cell should not be under load when this calibration method is used since a shunt value will be measured and recorded for later use with the "Cal Check" feature described above. The "No Masses Ready" message is intended to remind you of this fact.

>>Cal by Masses

This item is used to calibrate a load cell, channel A, using two known masses. Before you enter in the desired information, another menu will ask if you want to calibrate by **2 Point** or **5 Point**. You will then be asked for the channel, the load cell serial number, the date, the calibration unit, the cell's maximum rated load, and the desired excitation voltage (5.0 or 10.0 volts). You are then prompted to enter the value of the first mass. The "Mass 1 Ready?" message will wait while you actually hang the mass. When the Model 4215 is reading the load cell it will display the "Reading..." message for about 10 seconds. During this time it is important that the masses are not disturbed since all the readings taken are averaged together to obtain the calibration data. The second mass is then entered and read. If **5 Point** calibration was selected, the process will continue until all masses have been read. A "No Masses" reading is also required during which time a shunt check value is recorded.

>>Cal by Shunt Val

This item is used to calibrate a load cell using the manufacturer's shunt calibration factor expressed in pounds. You will be asked for the channel, the load cell serial number, the date, the calibration unit, the cell's maximum rated load, the desired excitation voltage (5.0 or 10.0 volts), and the shunt calibration constant. The Model 4215 will then automatically perform the shunt calibration of the load cell using its internal precision shunt resistor. Note that there is a back panel switch that allows you to select either a 30K or 60K resistor for shunt measurements (see Appendix B for a circuit diagram). Be sure to select the appropriate value for your load cell. During this calibration the "Reading..." message will be displayed. Do not disturb the load cell while it is being read. Like the "Cal by mV/volt" option, the load cell should be free of load during this calibration.

>>Counts per Inch

This entry allows you to set the number of counts per inch that the quadrature encoder input will use.

>Limits

This menu is used to set up the 4 contact closure switches. Instead of a submenu there are a series of selections. Pressing Enter will accept the displayed entry. Pressing Escape will return to the setup mode main menu without changing the limit setup.

1. **Select Limit X** -- The first selection chooses which of the limits you want to set up (1-4). Use the left/right or plus/minus buttons to change the number. Press enter to accept the displayed number. Press escape to return to the setup mode main menu.
2. **Normally Open / Closed** -- This selection determines if the switch contacts are open or closed when the limit is de-activated.
3. **Enabled / Disabled** -- Choosing enable allows the limit to operate as specified by the following selections. Choosing disable places the limit in its "normal" state and completes the limit setup.
4. **Source:** -- This selection allows you to scroll through a list (use either the left/right or plus/minus buttons) to select the source of the data that will drive the limit. The standard list will include load, peak, valley, position, velocity and, optionally, average force. Press enter to select the displayed item.
5. **Units:** -- This entry allows you to scroll through the list of available units for the data source you have chosen in the previous step.
6. **Set** -- This is the numerical value of the source at which the limit will be activated (set point). It is specified in the units you chose in the previous step.
7. **Trip if source </> Set** -- Choosing source>set means that the limit will be activated when the source becomes larger than the set point. Choosing source<set means the limit will be activated when the source becomes less than the set point.
8. **Latching on/off** -- Selecting latching off means that the limit will be de-activated automatically when the source passes the reset point (see next selection). Selecting latching on means that once the limit is activated you must manually reset it using the Reset button. If you select latching on then the limit setup is done.

9. **Rst** -- This selection determines the numerical value of the source at which the limit will be deactivated (reset point). If you selected "source>set" in step 7 then the limit is deactivated when the source is less than the reset point. If you selected "source<set" in step 7 then the limit is deactivated when the source is greater than the reset point.

Notes:

The Set and Reset conditions for each limit are evaluated independently. If both conditions are met then Reset will take priority over Set.

Limit status may show an asterisk if the limit is enabled but there is an error in the signal source. For example, if the limit source is load but there are no load cells currently calibrated, or the load cell has a rating of 0.0 Lb, or a millivolt per volt constant of zero. Another example would be if the limit source is position and zero has been entered for the encoder counts-per-inch constant. Limits that are in this error condition will be forced to the off position as if they were disabled.

>System Options

This menu contains some system wide parameters that are seldom changed. These are listed in a submenu that works exactly like the setup mode main menu.

>>Printer Baud

The front panel print button and the RS232 print commands will use this baud rate for communication with your printer. This setting has no effect on units that are not equipped with the printing option. 57.6 K baud is commonly used on older serial printers 230.4 K baud is used on more recent serial printers.

>>Auto Identify

This allows you to turn automatic load cell identification on or off. Usually you can leave auto-id on even if you never use automatic load cell identification. In order to use this function you must either have an auto-id equipped load cell or use an in-line auto-id module attached to your load cell cable.

>>Auto Zero Ch A/B

This menu lets you enable or disable auto zeroing for load measurements on Channel A or B. When enabled this function will tare the load to zero any time that it has remained within 10 counts of zero on the display for 10 seconds.

>>Com Address

This item allows you to set the address of this unit used for the RS232 ASCII command set. Valid values are 1 through 254. If the RS232 multi-drop option is installed you must be sure that all the attached units have different addresses to prevent data collisions.

>>Com Baudrate

This sets the baud rate for the RS232 ASCII command set. Available values are: 300, 600, 1200, 2400, 4800, 9600, and 19.2k. Note that the "Special" entry is reserved for future use.

>>Com Line Feed

This controls whether a line feed is added to each carriage return that is sent out by the Model 4215 when the RS232 ASCII command set is being used.

>>Retain Tare

This controls whether the most recent tare value is retained through power down of the unit and used again immediately on power up. Choosing this option will retain tare on channel A in a single channel unit and both channels A and B in a two-channel unit.

>Display Options

This menu contains options that effect how load, peak, and valley are displayed and printed. These are listed in a submenu that works exactly like the setup mode main menu.

>>Filter Select

There are two types of filters available on the Model 4215: Type I, and Type II. Type I filters are good for removing most kinds of noise but may leave some jitter on the end digits. Type II are more advanced filters that are optimized for the typical industrial environment. Both filter types allow you to select from 4 levels of filtering with Level 1 being the least filtering and Level 4 being the most filtering.

The settling time for each of the 4 levels of filtering is shown in the table below

Level	1	2	3	4
Settling Time (seconds)	<1	2	10	30
Read Rate (per second)	60	60	30	10

>>Decimals Ch A/B

This lets you set the maximum number of digits to the right of the decimal that are displayed or printed for load, peak, and valley. When large load cells are selected the number of decimal digits shown may be limited, for example a 100 Lb cell will allow 3 digits, while a 1000 Lb cell will only allow 2 digits. Also if a number is too large to fit on the display some decimal digits may be dropped (the display will "auto-range"). The number of digits shown for position data depends only on the number of counts per inch of the encoder and is not effected by this setting.

>>Count By Ch A/B

This allows you to choose the smallest unit of counting for the display of load, peak, and valley. Counting by 1, 2, 5, 10, and 20 are the options.

Note that the operation of the analog outputs and the limits is not effected by the settings of "decimal point" or "smallest count". Thus if you set a limit to be activated at 10.001 Lbs, and have "smallest count" set for 20, the limit is activated at 10.001 Lbs even though the display is only showing 10.000.

>>Second Line

This option allows you to choose what you want to have displayed on the second line. You can select limits, select a display, select text, or leave the line blank.

REMOTE OPERATION

Digital Inputs

There are 4 digital inputs available on the Model 4215. They are accessible on the Digital I/O connector on the back panel (pins 9 - 16). These inputs are individually opto-isolated and include current limiting resistors. An input voltage anywhere from +4 to +22 volts DC may be used to obtain the "on" state. See Appendix B for a full description of the Digital I/O connector.

If you do not require isolation for your application you can use the +5 or +12 volt and GND available on the Digital I/O connector (pins 24-26).

These 4 inputs are called IN1 through IN4 and have the following standard functions:

IN1 will Tare the Load to zero while it is in the On state.

IN2 will Reset the Peak and Valley measurements while it is in the On state.

IN3 will Reset the Position measurement while it is in the On state.

IN4 will send one set of measurements (load, peak, valley, position, velocity, and limits) to the serial printer when it transitions from Off to On.

Other functions may be assigned to these inputs by custom programming at the factory.

RS232 Operation

All the features and settings of the Model 4215 can be accessed remotely using the RS232 ASCII command set. These commands fall into two groups: commands that are like Run Mode, and commands are like Setup Mode.

The Model 4215 supports remote operation using a standard RS232 Interface consisting of ASCII characters. The baud rate is set using the Com Baudrate item on the System Options menu. Supported rates are **300, 600, 1200, 2400, 4800, 9600**, and **19.2k** baud. There must be **8 data** bits, **no parity**, and **1 stop** bit.

To support the multi-drop RS232 option each unit is assigned a communications address which is set using the Com Address item on the System Options menu.

All the commands have the following format:

@123XYZ<CR>

The @ symbol initiates the command, all commands must begin with this symbol. The number 123 is the address of the Model 4215 which should respond to this command. This **MUST** be 3 digits so type 001 for unit one, and 026 for unit twenty-six. The command itself will be a sequence of letters such as the XYZ shown above. If the command requires a number as one of its parameters the number must be followed by the pound sign "#". Numbers that are less than one should include a leading zero so you should type 0.123# to enter one-hundred twenty three thousandths. Commands are not processed until a carriage return <CR> is sent.

No Model 4215 will respond to address 000. All Model 4215's will respond to address 255. Throughout the rest of this section we will assume that you are using address 123.

Whenever an Model 4215 executes a remote command it will issue an acknowledge that includes the address and any required data.

RS232 RUN MODE COMMAND SUMMARY

@(addr)		
└─┘	H	Hello fetches unit description
└─┘	?	Get item and unit numbers
└─┘	FV	View item and unit settings
└─┘	FS (item)(unit)	Set displayed item and unit
└─┘	FA	Alternate display, like view button
└─┘	V (item)(unit)(repeat)	Get Value of an item and unit
└─┘	P (repeat)	Print a set of readings
└─┘	R (tare)(peak)(vall)(pos)	Reset readings
└─┘	T (hold)(text)	Place text on display

RS232 RUN MODE COMMANDS

The commands listed in this section mirror (and in some cases extend) the functions that are available from the front panel of the Model 4215 when it is in Run Mode.

Each entry will include the name of the command, followed by a short description that includes the command format, an example that shows what you would type (shown in plain font) and what the Model 4215 would return (shown in italics).

Hello Command (H)

This command fetches the model, version, and serial number of any unit at the specified address.

Example:

@123H

Acknowledge:

@123 *ESL Model 4215 Version 4.4.0 Serial #-980500*

Question Mark Command (?)

This command returns a list of item numbers and unit numbers that are available on the Model 4215 that is addressed. These numbers are used as arguments for the many of the commands shown below.

Example:

@123?

Acknowledge:

@123 *These are the Item numbers:*

00 - Load A	01 - Peak A	02 - Vall A	03 - Load B
04 - Peak B	05 - Vall B	09 - Pos	10 - Vel
13 - Limits	14 - Avg A	15 - Avg B	

These are the units for Load, Peak, and Valley:

00 - Lb	01 - kg	02 - N	03 - PSI
04 - MPa	05 - Klb	06 - kN	07 - t
08 - mVv	09 - g		

These are the units for Position:

00 - In	01 - Cm	02 - %
---------	---------	--------

These are the units for Velocity:
00 - I/M 01 - C/M

Front Panel Display Command (F)

This command is used to set the front panel display of the Model 4215 to a desired combination of item and unit. There are three subcommands: Front panel View (FV), Front panel Set (FS), and Front panel Alternate(FA).

Front Panel View Command (FV)

The Front panel View (FV) command just tells you what is currently on the display, and what will be displayed when the View button on the front panel is pressed.

Example:

@123FV

Acknowledge:

@123 *Active Display shows Load A in Lb*
Other Display shows Peak A in Lb

Front Panel Set Command (FS)

The Front panel Set (FS) command allows you to specify the item number and unit number for what is currently on the front panel display. The format is FS (item number)(unit number), where the first item and unit numbers are 2 digits each and may be found using the question mark command (?).

Example:

@123FS0200

Acknowledge:

@123 *Active Display shows Vall A in Lb*
Other Display shows Peak A in Lb

Front Panel Alternate Command (FA)

The Front panel Alternate (FA) command allows you to switch between the currently displayed item and unit and the alternate item and unit just as if you had pressed the View button.

Example:

@123FA

Acknowledge:

@123 *Active Display shows Peak A in Lb*
Other Display shows Vall A in Lb

Value Command (V)

This command is used to read the numerical value of a desired item and unit without altering the front panel display. The format is V(item number)(unit number channel A)(unit number channel B)(repeat), where the item and unit numbers can be found using the question mark command (see above), and the repeat number must be 0,1, or 2. Choosing repeat 1 will make the tester send you the desired value once. Choosing repeat 2 will make the tester send the value at approximately 3 second intervals. Choosing repeat 0 will turn off any values that are being sent by a repeat 2 command.

Item numbers have been added that apply to *this command only*. They are 50 (Load AB), 51(Peak AB), and 52 (Valley AB) and are viewable with the "?" command.

Example:

@123V01021

Acknowledge:

@123 Peak A 55.676 N

Example 2:

@123V5000002

Acknowledge 2:

@123 Load A 120.45 Lb Load B 99.02 Lb

@123 Load A 125.29 Lb Load B 99.02 Lb

.....

@123 Load A 137.81 Lb Load B 99.02 Lb

Example3:

@123V01021

Acknowledge3:

@123 Peak A 55.676 N

Example 4:

@123V00002

Acknowledge 4:

@123 Load A 120.45 Lb

@123 Load A 125.29 Lb

.....

@123 Load A 137.81 Lb

Print Command (P)

The print command will fetch a full set of readings (like pressing the front panel print button). These will be in the units that are currently selected on the numerical display. The format is P(repeat number), where the repeat number must be 0, 1, 2, or 3. Repeat 1 will return 1 set of readings to the RS232 terminal. Repeat 2 will return a set of readings approximately every three seconds (like the value command). Repeat 0 will turn off printing that was started with repeat 2. Repeat 3 will send one set of readings to the serial printer attached to the Model 4215 instead of to the RS232 terminal.

Example:

@123P1

Acknowledge:

@123 Load A 45.625 Lb
Peak A 82.396 Lb
Vall A -0.005 Lb
Load B 22.560 Lb
Peak B 23.000 Lb
Vall B -0.0001 Lb
Pos 3.500 In
Vel 0.0 I/M
Avg A 0.000 Lb
Avg B 0.000 Lb
Limits 0 0 0 1

Reset Tare, Peak, Valley, or Position Command (R)

This command allows you to reset the tare, peak, valley, or position readings. The format is R(tare A)(peak A)(valley A) (tare B)(peak B)(valley B) (position select), where the selects are either a 0 (don't reset) or a 1 (reset). Thus you can reset any combination of these readings with a single command.

Example:

@123R1000000

Acknowledge:

@123 Reset - Tare A

Example 2:

@123R0111000

Acknowledge 2:

@123 Reset - Peak A Valley A Tare B

Text Display Command (T)

This command allows you to put a line of text on the front panel display of the Model 4215. The format is T (text), where text is the message that you want to display. The text is limited to the number of characters that can be shown on the front panel display.

Example:

@123TStress Test Ready

Acknowledge:

@123 Text Displayed - Stress Test Ready

RS232 SETUP MODE COMMAND SUMMARY

@(addr)	U	V	User Data Entry
		A (channel)(number) #	View current settings
		L (number) #	Set Base Area Set Base Length
	A	V	Analog Output
		S (item)(unit)(full)#(zero)#	View current settings Set analog output
	S	V	Sensor Select
		S (channel)(serial number)#	View current sensor
		D (serial number)#	Select sensor by S/N Delete sensor by S/N
	C	C	Calibration
		B (see text for format)	Shunt Check load cell
		E	Begin sensor calibration
		V (mv/v constant)#	Escape sensor calibration
M (Number of Points/Masses)		Calibration by mV/volt	
M P1(mass 1)#		Calibrate by points	
M P2(mass 2)#		Calibration Mass 1	
M P3(mass 3)#		Calibration Mass 2	
M P4(mass 4)#		Calibration Mass 4	
M P5(mass 5)#		Calibration Mass 4	
M P0		Calibration Mass 5	
S (shunt value Lb)#	Calibration No Mass Calibration by Shunt Value		
I	V	Encoder counts per Inch	
	S(number)#	View counts/inch Set counts/inch	
L(lim)	V	Limits	
	S (see text for format)	View current settings	
	R	Setup limit Escape from limit setup Manual reset for latch	
O	V	System Options	
	P (baudrate code)	View current settings	
	I (0 or 1)	Printer baudrate	
	Z (channel)(0 or 1)	Auto-Identify load cells	
	A (new address)#	Auto-Zero load	
	B (baudrate code)	Com Address	
L (0 or 1)	Com Baudrate Com Linefeed		
D	V	Display Options	
	F (type)(level)	View current settings	
	D (channel)(number digits)	Filter select	
	C (channel)(countby code)	Decimal digits max	
	2 (B, L, T, or D)	Smallest count 2nd line shows a blank line, limits, text, or a display.	
T (text)	Set the text displayed on line 2.		

RS232 SETUP MODE COMMANDS

The commands in this section allow you to change the setup of the Model 4215. You will notice that these commands form a menu which exactly duplicates the Setup Mode menu used during setup of the Model 4215 from the front panel.

If the optional Keylock is installed and locked you will not be to alter the setup until the unit has been unlocked. The acknowledge will indicate this fact:

@123 Setup is Locked - use Keylock to unlock

User Data Entry Command (U)

This command is used to view or set the options in the user data entry menu, namely the base area (used to calculate load in PSI, or MPa) and base length (used to calculate position in %). This command has three subcommands: User data View (UV), User data Area (UA), and User data Length (UL).

User Data View Command (UV)

The User data View (UV) command has the format UV.

Example:

@123UV

Acknowledge:

*@123 Base Area Ch A is 1.00000 sq-in
Base Area Ch B is 0.50000 sq-in
Base Length is 3.0000 in*

User Data Area Command (UA)

The User data Area (UA) command is used to set the base area. The format is UA(channel)(number)#.

Example:

@123UAA1.0025#

Acknowledge:

@123 Base Area Ch A is 1.0025 sq-in

User Data Length Command (UL)

The User data Length (UL) command is used to set the base length. The format is UL(number)#

Example:

@123UL2.5#

Acknowledge:

@123 Base Length is 2.5000 in

Analog Output Command (A)

This command is used to view or set the analog output of the Model 4215. There are two subcommands Analog View (AV) and Analog Set (AS).

Analog Output View Command (AV)

The Analog View (AV) command has the format AV. It will return the current settings of the analog output.

Example:

```
@123AV
```

Acknowledge:

```
@123 Analog Output A is Load A in Lb
    10.0 Volts indicates 500 Lb
    0.0 Volts indicates 0.00 Lb
@123 Analog Output B is Load B in Lb
    10.0 Volts indicates 1000 Lb
    0.0 Volts indicates 0.00 Lb
```

Analog Output Set Command (AS)

The Analog Set (AS) command is used to change the settings of the analog output. The format is AS(channel) (item number)(unit number)(full scale)#(zero scale)#, where the channel is the analog output channel. The item and unit numbers are used to determine the signal source for the analog output. The full scale number indicates what signal level is assigned to full scale analog output of 10.0 volts, and the zero scale number indicates the signal level assigned to zero volts analog output.

Example:

```
@123ASA0000500.0#0#
```

Acknowledge:

```
@123 Analog Output A is Load A in Lb
    10.0 Volts indicates 500 Lb
    0.0 Volts indicates 0.00 Lb
@123 Analog Output B is Load B in Lb
    10.0 Volts indicates 1000 Lb
    0.0 Volts indicates 0.00 Lb
```

Sensor Command (S)

This command is used to view or select calibration data from the list of calibrated load cells maintained by the Model 4215. There are 4 subcommands, Sensor View (SV), Sensor List (SL), Sensor Select (SS), and Sensor Delete (SD).

Sensor View Command (SV)

The Sensor View (SV) command has the format SV. It returns information about the currently selected load cell including the serial number, the maximum load rating, the millivolt per volt calibration constant, the excitation voltage used, the latest date of calibration, and the shunt value recorded during that calibration.

Example:

@123SV

Acknowledge:

```
@123 This is the list of load cell calibration data:
  Ch A = S/N 123456, 100.00 Lb      , 3.00150 mV/v,
          10.00 V      , Cal on Oct27-99, 49.532 Lb Shunt
  unused S/N 13368, 10.00 Lb      , 3.00121 mV/v,
          10.00 V,      Cal on Oct27-99, 4.9292 Lb Shunt
  unused S/N 63220, 100.00 Lb      , 2.99984 mV/v,
          10.00 V      , Cal on Oct27-99, 49.381 Lb Shunt
  Ch B = S/N 89991, 1000.0 Lb      , 4.50015 mV/v,
          5.00 V      , Cal on Oct27-99, 486.45 Lb Shunt
```

Sensor Select Command (SS)

The Sensor Select (SS) command is used to select the calibration data for a stored load cell using the load cell serial number. The format is SS(channel)(serial number)#.

Example:

@123SSA13368#

Acknowledge:

```
@123 This is the list of load cell calibration data:
  unused S/N 123456, 100.00 Lb , 3.00150 mV/v, 10.00 V,
  49.532 Lb Shunt
  Ch A = S/N 13368, 10.00 Lb , 3.00121 mV/v, 10.00 V,
  4.9292 Lb Shunt
  unused S/N 63220, 100.00 Lb , 2.99984 mV/v, 10.00 V,
  49.381 Lb Shunt
  Ch B = S/N 89991, 1000.0 Lb , 4.50015 mV/v, 5.00 V,
  486.45 Lb Shunt
```

Sensor Delete Command (SD)

The Sensor Delete (SD) command is used to remove the calibration data for a stored load cell from the list. The format is SD(serial number)#.

Example:

@123SD13368#

Acknowledge:

```
@123 Deleted Sensor S/N 13368
  Ch A = S/N 123456, 100.00 Lb , 3.00150 mV/v, 10.00 V,
  49.532 Lb Shunt
  unused S/N 63220, 100.00 Lb , 2.99984 mV/v, 10.00 V,
  49.381 Lb Shunt
  Ch B = S/N 89991, 1000.0 Lb , 4.50015 mV/v, 5.00 V,
  486.45 Lb Shunt
```

Calibration Command (C)

This command has 8 subcommands. Calibration Check (CC) is used to run a shunt calibration check on a load cell. Calibration Begin (CB) starts the calibration of a new or existing load cell. Calibration by millivolt-per-Volt (CV) runs a calibration using the load cell mv/volt constant. Calibration by Masses (CM) does a two or five point mass calibration. Calibration by Shunt (CS) does calibration based on the shunt value of the load cell. Calibration Escape (CE) cancels a calibration that is underway. Calibration counts per Inch View (CIV) displays the current setting of the encoder counts per inch constant, and Calibration counts per Inch Set (CIS) lets you set the encoder counts per inch constant.

Calibration Check Command (CC)

The Calibration Check (CC) command runs a calibration check on the currently selected load cell. Note that the load cell should not be under load when this check is run. During the 10 second shunt calibration the front panel will show "RS232 Cal Check". After the 10 seconds the unit will return to run mode and send the acknowledge line shown below. This indicates both the current reading of the shunted load cell and the reading that was recorded when this load cell was last calibrated.

Example:

@123CCA

Acknowledge:

@123 Cal Check Ch A, S/N 123456
 Shunt Value is 49.532 Lb
 Cal Value was 49.531 Lb

Calibration Begin Command (CB)

The Calibration Begin (CB) command is a 4 part command used to start a calibration by any method. You must issue a CB command before trying calibration by mv/volt, masses, or shunt (CV, CM, or CS). While the Model 4215 is being calibrated using the remote commands, the front panel will show "RS232 CAL STARTED". Pressing the front panel Esc button will cancel the calibration and issue a warning to the RS232 terminal. If any remote commands other than calibration commands are issued the calibration will also be canceled. The acknowledge will indicate if this is a "New Load Cell" or if you are going to "Overwrite" existing data. If you do not wish to overwrite use the CE command to stop this calibration. Another method of overwriting existing data is to delete the sensor first and then calibrate.

The format for the CB commands are

CB1(space)(channel)(serial number)#
 CB2(space)(month)(day)(year)
 CB3(space) (excitation)(calibration unit)
 CB4(space)(rated load)#

where channel is A or B, serial number is the serial number of the load cell, not exceeding 6 digits, month, day, and year are 2 digit numbers to represent the current date, excitation should be a 0 for 5.00 volts or a 1 for 10.00 volts, and calibration unit is the desired unit for this calibration, and rated load is the maximum load rating for the load cell.

Example 1:

@123CB1 A123456# 1000.0#

Acknowledge 1:

@123 Calibrate Begin 1 Command - New
Load Cell S/N: 123456 - Channel A

Example 2:

@123CB2 042298

Acknowledge 2:

@123 Calibrate Begin 2 Command - New
Cal Date: Apr22-98

Example 3:

@123CB3 100

Acknowledge 3:

@123 Calibrate Begin 3 Command - New
Excitation Voltage: 10.0 V, Calibration Unit: Lb

Example 4:

@123CB4 1000.0#

Acknowledge 4:

@123 Calibrate Begin 4 Command - New
Rated Load: 1000.0 Lb

Calibration Escape Command (CE)

The Calibrate Escape (CE) command is used to cancel a calibration that was started with the Calibrate Begin (CB) command. This format is CE.

Example:

@123CE

Acknowledge:

@123 Calibrate Command - Canceled, Calibration NOT Changed

Calibrate by Millivolt-Per-Volt Command for One Point (CV)

The Calibrate by milli-volt per Volt (CV) command is used to calibrate a load cell using its millivolt per volt calibration constant. You must have already started a calibration using the CB command for this command to function. The format is CV(millivolt per volt constant)# Note that a shunt check calibration will also be run at this time and so it is important that the load cell is not under load when this command is entered.

Example:

@123CV4.5002#

Acknowledge:

@123 Calibrate Command - Reading for Shunt Check...

[10 seconds delay]

@123 Calibrate Command Completed

Ch A = S/N 123456, 1000.0 Lb , 4.50020 mV/v,
10.00 V , Cal on Oct27-99, 553.26 Lb Shunt
unused S/N 63220, 100.00 Lb , 2.99984 mV/v,
10.00 V , Cal on Oct27-99, 49.381 Lb Shunt

*Ch B = S/N 89991, 1000.0 Lb , 4.50015 mV/v,
5.00 V , Cal on Oct27-99, 486.45 Lb Shunt*

Calibrate by Millivolt-Per-Volt Command for Five Points (CMV5)

The Calibrate by milli-volt per Volt for five points (CMV5) command is used to calibrate a load cell using 5 points of mass and milli-volt per volt each. You must have already started a calibration using the CB command for this command to function. The format is CMV5. Note that a shunt check calibration will also be run at the end of the calibration and so it is important that the load cell is set at 0 (or no masses) when the final command is entered.

Example:

@123CMV5

Acknowledge:

*@123 Calibrate by mV/Volt - 5 Point
Ready for Mass CMVM1 command*

Calibrate by mV/V Mass and Volt Commands (CMVM and CMVV)

The Calibration by mV/V Mass (CMVM) and Volt (CMVV) commands can have up to six parts each: CMVM1 through CMVM5, and CMVM0; and CMVV1 through CMVV5, CMVV0. You must have already started a calibration using the CB and CMV5 commands for any of these commands to function. To input the first mass issue the Calibration by mV/V Mass 1 (CMVM1) command. The mass is entered using the following format: CMVM1(mass value)#. Entering this command will result in the unit prompting the user for the first milli-volt per volt command.

Example:

@123CMVM15.0005#

Acknowledge:

*@123 Calibrate Mass 1 Command entered
Ready for mV/V Value CMVV1 or CE command*

The CE or Calibration Escape command will, if entered, end this calibration without calibrating the unit. The unit will remain calibrated according to the most recent calibration or, if this is the first calibration of the unit, the unit will remain uncalibrated.

At this point the unit is prompting the user for the first milli-volt per volt value of the calibration. The mV/V value is entered using the Calibration by mV/V Volt Command with the following format: CMVV1(mV/V value)#.

Example:

@123CMVV11.9926#

Acknowledge:

*@123 Calibrate mV/V 1 Command entered
Ready for Mass Value CMVM2 or CE command*

The unit will continue to prompt the user for mass and milli-volt per volt values until the five points have been entered. Then the user will see the following acknowledgement:

@123 Calibrate mV/V 5 Command entered
Ready for Mass Value CMVM0 or CE command

The user must now enter the CMVM0 command to finish the calibration. Note the load cell should have no masses on it at this point since a shunt calibration is run.

Example:

@123CMVM0

Acknowledge:

@123 Calibrate Command - Reading for Shunt Check...
[10 seconds delay]

@123 Calibrate Command Completed
Ch A = S/N 123456, 1000.0 Lb , 4.50020 mV/v,
4.50020 mV/v,
4.50020 mV/V,
4.50020 mV/V
4.50020 mV/V
5.00 V , Cal on Oct27-99, 553.26 Lb Shunt

Calibrate by Masses Command (CM)

The Calibrate by Masses (CM) command tells the unit that you are doing a calibration by 2 point or 5 point mass. The format is CM2 for a two point mass calibration and CM5 for a 5 point mass calibration.

Example:

@123CM5

Acknowledge:

@123 Calibrate by Mass - 5 Point
Ready for CMP1 command

Calibrate by Masses Point Command (CMP)

The Calibration by Masses Point (CMP) command can have up to six parts: CMP1 through CMP5 and CMP0. You must have already started a calibration using the CB and CM commands for any of these commands to function. To read the first mass issue the Calibration Mass Point 1 (CMP1) command. The format is CMP1(mass)#. This will cause the Model 4215 to read 10 seconds of data from the load cell. These readings are averaged to obtain the first calibration mass reading. The example uses 0.0 Lb for the first mass. Be sure you have placed the mass on the load cell before entering this command since reading will begin immediately.

Example:

@123CMP10.0#

Acknowledge:

@123 Calibrate Mass 1 Command - Reading...
[10 seconds delay]
Calibrate Mass 1 Command - Ready for CMP2 or CE command

The Calibrate Mass 2 (CMP2) command has the format CMP2(mass)#. This command can only be issued after the CMP1 command has completed. The example uses 500 Lb for the second calibration mass. Be sure you have placed the

mass on the load cell before entering this command since reading will begin immediately.

Example:

@123CMP2500#

Acknowledge:

@123 Calibrate Mass 2 Command - Reading...

[10 seconds delay]

Calibrate Mass 2 Command - Ready for CMP3 or CE command

Masses three through five are done in a similar manner. The Calibrate Mass Point 0 (CMP0) command completes the 2 or 5-point mass calibration. Remove the masses from the load cell before entering this command since it will perform the shunt calibration measurement that is recorded for use with the calibration check command. The format is CMP0.

Example:

@123CMP0

Acknowledge:

@123 Calibrate Command - Reading for Shunt Check...

[10 seconds delay]

@123 Calibrate Command Completed

```

Ch A = S/N 123456, 100.00 Lb      , 3.00150 mV/v,
                                     3.00230 mV/v,
                                     3.00238 mV/v,
                                     3.00353 mV/v,
      10.00 V      , Cal on Oct27-99, 49.532 Lb Shunt
unused S/N 13368, 10.00 Lb      , 3.00121 mV/v,
      10.00 V      , Cal on Oct27-99, 4.9292 Lb Shunt
unused S/N 63220, 100.00 Lb     , 2.99984 mV/v,
      10.00 V      , Cal on Oct27-99, 49.381 Lb Shunt
Ch B = S/N 89991, 1000.0 Lb     , 4.50015 mV/v,
      5.00 V      , Cal on Oct27-99, 486.45 Lb Shunt
    
```

Calibrate by Shunt Command (CS)

The Calibrate by Shunt (CS) command is used to calibrate the load cell using the shunt calibration factor expressed in pounds. This command will only function if you have already issued a Calibrate Begin (CB) command. Note that the load cell should not have any load on it for this command to operate correctly. The format is CS(shunt value in Lb)#. The example shows calibration using a shunt value of 553.26 Lb.

Example:

@123CS553.26#

Acknowledge:

@123 Calibrate Shunt Command - Reading...

[10 seconds delay]

@123 Calibrate Command - Reading for Shunt Check...

[10 seconds delay]

@123 Calibrate Command Completed

```

Ch A = S/N 123456, 1000.0 Lb     , 4.50014 mV/v,
      10.00 V      , Cal on Oct27-99, 553.26 Lb Shunt
unused S/N 63220, 100.00 Lb     , 2.99984 mV/v,
      10.00 V      , Cal on Oct27-99, 49.381 Lb Shunt
Ch B = S/N 89991, 1000.0 Lb     , 4.50015 mV/v,
    
```

5.00 V , Cal on Oct27-99, 486.45 Lb Shunt

Calibrate Counts-Per-Inch Command (CI)

This command has two subcommands, a view command (CIV) and a set command (CIS).

The Calibration counts per Inch View (CIV) command displays the current setting of the encoder counts per inch constant.

Example:

@123CIV

Acknowledge:

@123 Encoder is 32000 counts per inch

The Calibration counts per Inch Set (CIS) command allows you to change the current setting of the encoder counts per inch constant.

Example:

@123CIS64000#

Acknowledge:

@123 Encoder is 64000 counts per inch

Limits Command (L)

This command allows you to view or set the 4 contact closure limit switches on the Model 4215. There are three subcommands Limit View (LiV), Limit Set (LiS), and Limit Reset (LiR).

Limit View Command (LiV)

The Limit View (LiV) command is used to view the current settings of one of the limits. The format is L(limit number)V.

Example:

@123L1V

Acknowledge:

@123 Lim 1 NO Enabled Load A Lb Set 20.00 Trip>Set Latch Off
Reset 1.000

This line indicates that Limit 1 is a normally open switch (NO) rather than a normally closed switch (NC). The limit is Enabled rather than Disabled. The signal driving this limit is Load in Lb. The limit will be turned on when the load exceeds 20.00 Lb. It is not a Latching limit (latching requires a manual reset). The limit will automatically reset when the load is less than 1.00 Lb.

Limit Set Command (LiS)

The Limit Set (LiS) command is broken up into 4 separate commands. They have the following format:

L(limit number)SA(space) (normal position)(enable)(item number)(unit number)

L(limit number)SB(space) (setpoint number)#

L(limit number)SC(space) (< or >)(latching)

L(limit number)SD(space) (reset point number)#

The limit number chooses which limit (1-4) you want to setup. The normal position should be set to 0 for normally open or 1 for normally closed. The enable should be set to 0 for disabled or 1 for enabled. If the limit is disabled the rest of this command may be omitted (see example 3). The item and unit numbers indicate which signal is to drive this limit. The set point number indicates the signal level at which the limit is to be activated. The < or > sign indicates whether you want the limit to be activated when the signal is greater than the set point (>) or less than the set point (<). The latching should be set to 0 for latching off or 1 for latching on. If latching on is selected the rest of the command may be omitted (see example 2). Latching on will require a manual reset once the limit has been activated. The reset point indicates the signal level at which the limit should be de-activated.

If you want to enable a limit without otherwise changing its settings you can enter L(limit number)SA(space)(normal position)1# instead of entering the full setup string (see example 4).

Example 1:

@123L1SA 010000

Acknowledge 1:

@123 *Limit Setup Command A - Ready for Command B*

Example 2:

@123L1SB 50.0#

Acknowledge 1:

@123 *Limit Setup Command B - Ready for Command C*

Example 3:

@123L1SC >0

Acknowledge 3:

@123 *Limit Setup Command C - Ready for Command D*

Example 4:

@123L1SD 10.0#

Acknowledge 4:

@123 *Lim 1 NO Enabled Load A Lb Set 50.00 Trip>Set Latch Off
Reset 10.00*

Example 5:

@123L1SA 10

Acknowledge 5:

@123 *Lim 1 NO Disabled Load A Lb Set 50.00 Trip>Set Latch
Off Reset 10.00*

Example 6:

@123L1SA 11#

Acknowledge 6:

@123 *Lim 1 NC Enabled Load A Lb Set 50.00 Trip>Set Latch Off
Reset 10.00*

Limit Setup Escape (LE)

The Limit Escape (LE) command is used to cancel a limit setup that was started with the Limit Set (LiS) command. This format is LE.

Example:

@123LE

Acknowledge:

@123 Limit Setup Command Canceled

Limit Reset Command (LiR)

The Limit Reset (LiR) command is used to manually reset a latching limit that has been activated. The format is L(limit number)R.

Example:

@123L1R

Acknowledge:

@123 Reset Limit 1

System Options Command (O)

The system Options command has 7 subcommands that are used to view or set the options that appear on the system options menu. Option View (OV) displays all the settings in the system options menu, Option Printer (OP) is used to set the printer baudrate, Option Auto ID (OI) is used to turn auto-identification of load cells on or off, Option Auto Zero (OZ) is used to turn auto-zeroing of load on or off, Option Com Address (OA) is used to change the communications address of the unit, Option Baudrate (OB) is used to change the communications baudrate, and Option Linefeed (OL) is used to turn the auto line feed option on or off. Option Tare retain (OT) is used to turn the tare retain option on or off. Each of these options is described below.

Option View Command (OV)

The Option View (OV) command returns a list of the current settings of all the system options. The format is OV.

Example:

@123OV

Acknowledge:

@123 Printer Baud Rate is 9600

Auto Identify is off

Auto Zero Channel A is off

Auto Zero Channel B is off

Com Address is 123

Com Baud Rate is 4800

Com Line Feed is off

Retain Tare is off

Option Printer Baudrate Command (OP)

The Option Printer baudrate (OP) command is used to select the printer baudrate. The format is OP(code) where the code is from the table shown at the right.

Example:

@123OP9

Acknowledge:

@123 Printer Baud Rate is 230.4K

Option Printer Command	
Code	Baudrate
4	4800
5	9600
6	19.2K
8	57.6K
9	230.4K

Option Auto-Identify Command (OI)

The Option auto-Identify (OI) command is used to turn auto-identification of load cells on or off. The format is OI(0 or 1), where 0 turns auto-id off, and 1 turns auto-id on.

Example:

@123OI0

Acknowledge:

@123 Auto Identify is off

Option Auto-Zeroing Command (OZ)

The Option auto-Zero (OZ) command is used to turn auto-zeroing of load on or off. The format is OZ(channel)(0 or 1) where channel is A or B and 0 & 1 turn auto-zeroing off and on, respectively.

Example:

@123OZA1

Acknowledge:

@123 Auto Zero Channel A is on
Auto Zero Channel B is off

Option Com Address Command (OA)

The Option com Address (OA) command is used to change the communications address assigned to this unit. The format is OA(new address)#. Note that valid addresses are 1 through 254.

Example:

@123OA3#

Acknowledge:

@003 Com Address is 003

Option Com Baudrate Command (OB)

The Option com Baudrate (OB) command is used to change the communications baudrate for this unit. The format is OB(code), where the baudrate codes are given in the table. Code 7 is a special baudrate that is reserved for future expansion. Note that the acknowledge is given at the current baudrate and then the baudrate is changed.

Option Baudrate Command	
Code	Baudrate
0	300
1	600
2	1200
3	2400
4	4800
5	9600
6	19.2K
7	Special

Example:

@123OB2#

Acknowledge:

@003 Changing Communications Baudrate to 1200

Option Linefeed Command (OL)

The Option com Linefeed (OL) command turns on or off the generation of linefeed characters when the Model 4215 sends information to your RS232 terminal. The format is OL(0 or 1), where 0 turns linefeeds off, and 1 turns them on.

Example:

@003OL1

Acknowledge:

@003 Com Linefeed is on

Option Tare Retain Command (OT)

The Retain Tare (OT) command enables and disables the retention of the current tare value in memory for use after the unit has been powered down and then powered back up. The format for the OT command is: OT(0 or 1), where 0 is disable and 1 is enable. Once enabled, the tare values are retained until this option is disabled. Disabling the tare retention option resets the tare values for both channels to 0.

Example:

@123OT1

Acknowledge:

@123 Retain tare is on

Display Options Command (D)

The Display options command has 5 subcommands used to set options that effect the front panel display of the Model 4215.

Display View Command (DV)

The Display View (DV) command is used to return the current values of all the display options. The format is DV.

Example:

@123DV

Acknowledge:

@123 Filter is Type II Level 2
 Channel A shows 4 decimal digits
 Channel B shows 4 decimal digits
 Channel A counts by 1
 Channel B counts by 1
 Second line shows limit status

Display Filter Command (DF)

The Display Filter (DF) command sets the filter type and level. The format is DF(type)(level), where type is either 1 for type I filters, or 2 for type II filters, level must be 1, 2, 3, or 4 depending on the level of filtering desired. (4 is most filtering and slowest rise time).

Example:

@123DF13

Acknowledge:

@123 Filter is Type I Level 3

Display Decimal Command (DD)

The Display Decimal (DD) command sets the maximum number of decimal digits that are shown for Load, Peak, and Valley. The format is DD(channel)(number), where channel is A or B and the number must be between zero and 5.

Example:

@123DDA0

Acknowledge:

@123 Channel A shows 0 decimal digits

Display Count By Command (DC)

The Display Count by (DC) command sets the smallest number that the display will count by for the Load, Peak, and Valley measurements. The format is DC(channel)(code) where the code is selected from the table at the right.

Display Count by Command	
Code	Count By
0	1
1	2
2	5
3	10
4	20

Example:

@123DCA3

Acknowledge:

@123 Channel A counts by 10

Display Second Line Command (D2)

The Display Second Line (D2) command is used to set the second line to be blank, or to show the limit status. The format is D2(B, L, D, or T), where B makes the line

blank, L makes the line show limit status, D makes the line show another display, and T makes the line show text.

Example:

@123D2B

Acknowledge:

@123 Second Line set to Blank

Display Second Line Text (DT)

The Display Second Line Text (DT) command is used to select the text that would be displayed on the second line if text was set to go on the second line.

Example:

@123DTESL Sense I

Acknowledge:

@123 Text Message - Model 4215

SYSTEM CALIBRATION MODE

The following procedure should be followed to calibrate the Model 4215 itself. This calibration requires the use of a precision millivolt per volt reference which will be attached on the load cell connector. The resulting scale factors are recorded in the non-volatile memory of the Model 4215.

ATTENTION: System Calibration should ONLY be performed by trained, QUALIFIED TECHNICIANS utilizing the proper precision devices to ensure the most accurate performance of the unit.

1. To enter system calibration mode, turn off the Model 4215. Hold down the two end buttons ("<" and ">") while turning power back on. As soon as the display comes on you can release the buttons.
2. The unit will go through its regular start up sequence but rather than entering run mode and showing the load in pounds a password prompt will be displayed. Enter the number 777 as the system calibration password.
3. The unit will now display "Unit mV / V Cal" to indicate that it is ready to be calibrated. *A five minute warm-up period with the millivolt-per-volt reference attached is recommended at this time if the unit has just been turned on or the millivolt-per-volt reference has just been attached.* Press any button to clear this display.
4. You are now prompted to enter the first of two millivolt per volt references. (We recommend using -3.0 mv/volt for the first and +3.0 mv/volt for the second.) Set your reference and enter the appropriate number. As soon as you press Enter the Model 4215 will start reading the reference.
5. Next you are prompted for the second mv/volt value. Set your reference and enter the appropriate number. Again reading will start as soon as Enter is pressed.
6. When the read is complete, the unit will display "Calibration Done". Pressing any button at this time will place the unit back into its normal run mode.

FORCE AVERAGING (OPTIONAL)

The Avg A and Avg B in the item menu is an optional Digital Input function for the display of Force Averaging. If this function is selected, it replaces **IN2** of the standard Digital Input function.

When first selected after power up, the value displayed for average force will be zero. To use the features, the user must activate the isolated input 2, **IN2**, of the Digital I/O port connector (pins 11 and 12 – see Digital I/O Connector in Appendix B). Once the Digital Input has been activated, the unit will begin to display a running average of the force measured after an approximately 2 second delay. The item “Avg A” refers to the average force measured, calculated, and displayed on channel A, and “Avg B” refers to the average force measured, calculated, and displayed on channel B. Opening the Digital Input circuit will stop the averaging. The final average value will remain on the display until the input is again activated or the unit is powered down.

If you do not require isolation for your application, you can use the +12 volt source and an available GND signal located on the Digital I/O connector (pin 26 and pin 24) to create a circuit that only needs contact open/closure to activate and deactivate the digital input. See the application diagram below.

APPLICATION DIAGRAM – Contact OPEN/CLOSE activation of Force Averaging

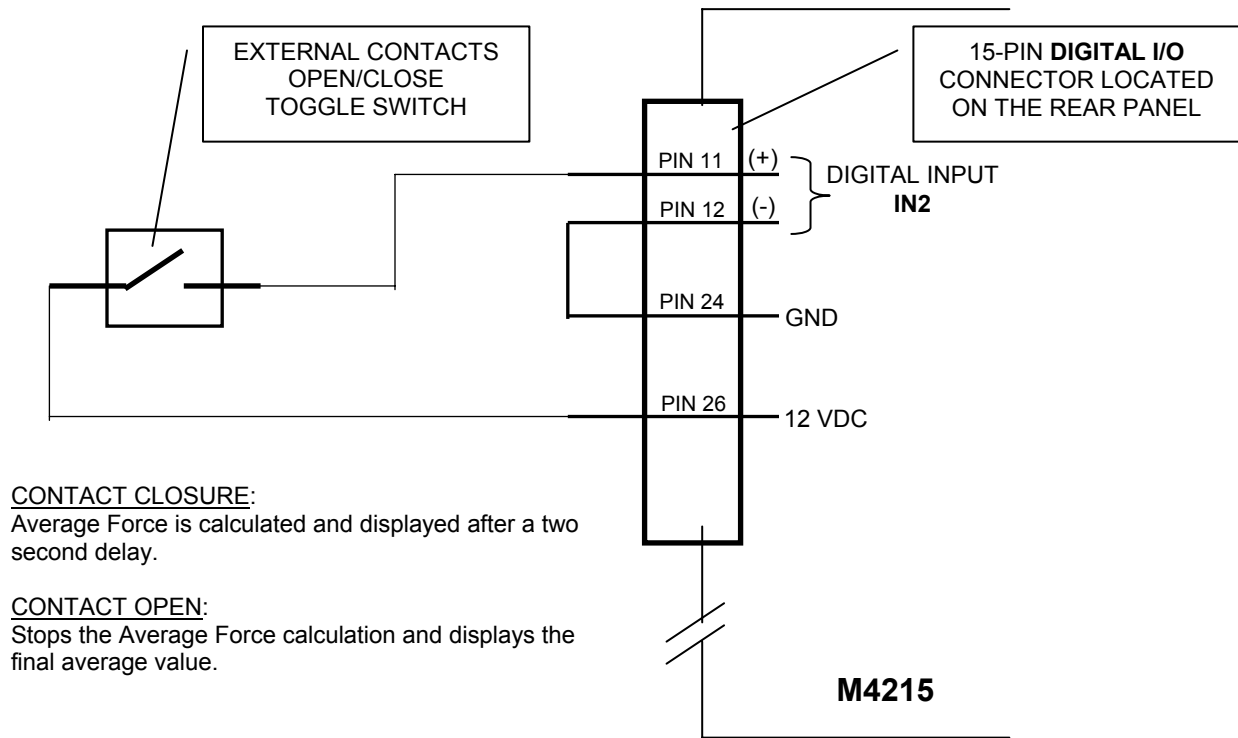

APPENDIX A – MODEL 4215 SPECIFICATIONS

Transducer Interface	
Excitation	5VDC or 10 VDC software/auto selectable
Current Drive	180 mA at 5VDC or 10 VDC
Push Button Shunt	Yes
Internal Shunt Resistor	1 standard, 2 optional. Rear panel selectable
Calibration Method	Shunt, mV/V, Known Load
Push Button Tare	100% of range--display and analog output
Sensitivity Adjust	1mV/V to 4.5 mV/V
Accuracy	0.01% of full scale +/- 1 digital count
CMRR	115 dB

Additional Transducer Channel	
Auxiliary Channel	optional

D/A Analog Output	
Full Scale Output	+/- 10 VDC nominal +/- 0.5 VDC
Linearity	0.02 % of full scale
Scaling	Gain and offset selected by software.
Frequency Response	Approx. 15 Hz (plus filtering)
Output Source	Any displayed quantity
Output Channels	1 std, 2 optional

Direct Analog Output	
Full Scale Output	-/+ 8.14 VDC +/- 0.25 VDC
Linearity	0.02 % of full scale
Scaling	Fixed with no tare, transducer channel only
Frequency Response	Approx. 1.5 kHz

Peak/Hold	
Peak/Valley/Hold	Digital 1/60 second capture

Digital I/O	
Digital Inputs	
Interface	4 optically isolated inputs
Function	remote tare, peak/valley reset, position reset, print
Digital Outputs	
Function	4 independent limits
Quad-Limits Setup	Front panel, latching or non-latching set points normally open/closed, enable/disable
Quad-Limits Output	4 isolated solid state switches
Quad-Limits Source	Any displayed quantity

Serial Interface	
RS-232 Serial Setup/Output	Standard
RS-485 Serial Setup/Output	Optional
Multi-drop RS-232	Optional

Printing	Optional
Interface Type	Serial
Quantities Printed	All displayed items

Encoder Position Channel	Optional
Encoder Type	Quadrature, 4X number of lines
Excitation	12 VDC std., 5 VDC optional
Interface	Single ended or differential
Calibration	User adjustable counts/inch

Auto Transducer Identification	
Auto Identification and Setup	Yes, standard

Push Buttons	
Smart Push Buttons	6
Adjustments	Displayed item, displayed units, tare, peak/valley reset alternate view, print. Alternate functions for programming.

Digital Display	
Display Characters	2 lines by 20 characters
Display Update	> 4/Sec
Scaling	Automatic or manual
Maximum Display Count	± 999,999
Decimal Points. Selection	0 to 5 software selectable.
Display Type	Vacuum fluorescent
Resolution	24 bit
Software Filters	8, software selectable

Electrical Characteristics	
Power Requirements	110 VAC, 60 Hz, Optional 220VAC, 50 Hz
Power Consumption	12 W (unloaded)
Transducer Excitation Current	Shutdown mode when shorted to ground
Absolute Max Transducer Input	30 VDC without damage

Physical Characteristics	
Package Size	10.0" X 3.0 " X 10.5" (W X H X D)
Case Material	Aluminum
Mounting Hardware	Available

Environmental	
Operating Temp	0 C to 50 C
Storage Temp	-10 C to 60 C
Relative Humidity	95 % without condensation

APPENDIX B -- CABLES AND CONNECTORS

Sensor Connectors

DB9 Female	
Pin	Signal
1	EXCITE - HI
2	SENSE - HI ¹
3	CELL OUTPUT - HI
4	CELL OUTPUT - LO
5	SENSE - LO ¹
6	EXCITE - LO
7	AUTO ID - A
8	AUTO ID - B
9	CHASSIS GND

Notes:

1. If the sense lines are not used, SENSE - HI must be tied to EXCITE - HI and SENSE - LO must be tied to EXCITE - LO.

Serial Port Connector

DB 15 Male	
Pin	Signal
1	TXD
2	RXD
3	No Connect
4	SERIAL GND
5	TXD+ (Printer)
6	TXD- (Printer)
7	RXD- (RS485)
8	RXD+ (RS485)
9	No Connect
10	SERIAL GND
11-13	No Connect
14	TXD+ (RS485)
15	TXD- (RS485)

Notes:

1. Pins 1,2 and 4 are used for RS232 ASCII command set communications. Use 8 data bits, no parity, 1 stop, and set the baud rate using the Com Baudrate entry on the System Options menu.

2. The printer uses RS422 differential signaling on pins 5, 6 and 10. Baud rate for the printer is selectable using the Printer Baud entry on the System Options menu.

3. Pins 7, 8, 14 and 15 are used for RS485 ASCII command set communications. Use 8 data bits, no parity, 1 stop, and set the baud rate using the Com Baudrate entry on the System Options menu.

Digital I/O Connector

Notes:

High Density 26 Female	
Pin	Signal
1	LIM 1 A ¹
2	LIM 1 B ¹
3	LIM 2 A
4	LIM 2 B
5	LIM 3 A
6	LIM 3 B
7	LIM 4 A
8	LIM 4 B
9	ISO IN 1 - HI ²
10	ISO IN 1 - LO ²
11	ISO IN 2 - HI
12	ISO IN 2 - LO
13	ISO IN 3 - HI
14	ISO IN 3 - LO
15	ISO IN 4 - HI
16	ISO IN 4 - LO
17	KEYLOCK ³
18	GND
19	ENCODER CHA-L ⁴
20	ENCODER CHA
21	GND
22	ENCODER CHB-L
23	ENCODER CHB
24	GND
25	GND
26	+12 VDC (+5 VDC optional ⁴)

1. Limits are optically isolated solid state switches that can control AC or DC voltage. Peak blocking voltage is 350V, maximum continuous current is 120 mA.

2. Digital inputs are opto-isolated with internal current limiting resistors. Voltage range is +4 to +22 VDC on the "HI" input with respect to the "LO" input. Other voltage ranges are possible with added external resistors, contact Electro Standards Laboratories for details. If isolation is not required these inputs may be operated using the +12 VDC supplied on pin 26 and the GND on pin 24.

3. The keylock input will be in the "unlocked" state if left unconnected. Tie this pin to GND to "lock" it. When locked the setup of the Model 4215 cannot be changed (you cannot enter Setup mode).

4. The encoder inputs are intended for use with a +12 VDC quadrature encoder. For single ended signaling use the CHA and CHB pins, the CHA-L and CHB-L pins are provided for differential signals. The encoder can be supplied with the +12 VDC and GND available on pins 26 and 24.

The Model 4215 will also accept +5 VDC encoder inputs but these MUST be differential. Single ended +5 VDC inputs are not supported on the standard unit. Options for +5 VDC encoders are available. Pin 26 will supply +5 VDC for this option and must be ordered accordingly.

Chart Rec. Connector

DB9 Male	
Pin	Signal
2	ANALOG - OUT ¹
3	ANALOG - GND
4	HIGH BANDWIDTH - OUT ² CHANNEL A
5	4-20 mA – OUT ³ CHANNEL A
6	2 nd ANALOG-OUT ¹ (Optional)
7	4-20 mA – OUT ³ CHANNEL B
8	HIGH BANDWIDTH - OUT ² CHANNEL B
9	No Connect

Notes:

1. The source and scaling of ANALOG - OUT is selected through the menus.
2. The HIGH BANDWIDTH - OUT is a buffered analog output permanently connected to the load cell channel.
3. If the 4-20 mA Option is purchased.

Precision Shunt Calibration Resistors

This diagram shows the connection of the precision internal shunt resistors.

The back panel switch (shown to the left of the two resistors) selects between 30 K Ω and 60 K Ω .

The shunt check relay (shown to the right of the two resistors) connects the selected resistor between the Excite High and the Cell Output High.

